

VETTE GAZETTE

Volume 4 Issue 1

March 2006

**Inside this
issue:**

What's Wrong With This Picture?	2
The Nuts and Bolts of Nuts and Bolts	5
Lost Owner	9
New 1957-1965 Corvette Fuel Meter Covers	10
Ads and Services	16
C3 Build Sheet Removal	17
'Chapter Officers'	19
First Annual Founders Day Dinner	21
Members Corner	24

Chairman's Corner with Larry Linder

Chairman's Corner:

It 2006 and we are officially 3 years old as chapter in the NCRS as of July. We have accomplished a lot, had fun with our cars, met a lot of great people and reunited some long forgotten acquaintances.

The events for 06 are going to be more numerous and varied. A number of social events are planned.

A couple of road tours to parks and pot luck dinners plus a number of trips are being planned, see the web site. The ladies assisting the events chairman are making the difference. It keeps us car nuts from spending all our time ogling parts.

By the time you read this our Founders Dinner will be history and you missed your chance to get a nice red 65 Fuel Injected coupe

with knock-offs, teak wheel, and telescoping steering col. that was given away at the dinner. There were a lot of other door prizes and a nice table center piece. You should have come and taken your chances.

We should know in while if we are successful in our bid for the 08 regional. Our 3rd judging meet will be held in June. The cruise in is going to advertised a little more and what we need is a battery operated PA system for music at the cruise in. I am also looking for a good original sound track for Route 66.

The directors are busy planning events, making sure that our chapter is growing, receives national recognition and provides members interesting thing to do. The year got off to

a good start with the NCRS regional at Kasseme, Flor-

ida - would you believe 5 perfectly restored 57 FI cars, a 68 L88, a low mile 64 FI coupe with 27K miles, all in a pack of over a



Feature Article

105 cars to be Judged. Al Katona should write a

Continued on page 19

What's Wrong With This Picture? *by Terry Brim*



What's wrong with this picture?.....for most people, absolutely nothing. If your Dale Felty however, it's a missing 1970 LT1. Dale has 71 LT1 and a 72 LT1 with a 1965 Fulie sandwiched in between!

What I love most about doing these feature articles is the answer I get to the first question I always ask which is "how did you get interested in corvettes?" ...In Dale's case, his answer was "because he got the crap scared out of him!"

It was 1972 and Dale, at the tender age of 15, had just come back to Dayton. Turns out, he was an Army brat and had moved around a lot.. Anyway, upon returning to Dayton Dale's cousin took him for a ride in his 1968 BB corvette converti-

ble.....The rest is history, Dale says he was scared to death during the ride, but when he got out of the car, he looked at the car and said "that's what I want, that's what I've gotta have!"

His dream fi-

What I love most about doing these feature articles is the answer I get to the first question I always ask which is "how did you get interested in corvettes?" ...In Dale's case, his answer was "because he got the crap scared out of him!"

to replace. In 1990, he bought a red 72' which he sold in 1995. Since then, Dale has owned about 15 corvettes. Dale loves the hobby, says he meets a lot of great people, as we all do and is glad he is in the club.

Of his current collection, Dale has had the 71' LT1 the longest. He bought the car in 2000 from a guy in Florida. Dale blew the motor back in 2004 (says he

wasn't really on it...only doing about a hundred and five.....lol), but luckily enough, he was able to save the block during the engine re-build.

He blew the motor back in 2004 (says he was wasn't really on it...only doing about a hundred and five.....lol)

The car is equipped with leather interior and a rare rear window defroster. Hr recently bought a hard top for the car (which is sitting on the 72 in the pictures) . Dale says even though the 71' is not equipped with power steering or power brakes, it is such a fun car to drive!

nally came true in 1989 when he bought a brand new 89' vette off the showroom floor. Dale says it is a feeling he will never be able

to replace. In 1990, he bought a red 72' which he sold in 1995. Since then, Dale has owned about 15 corvettes. Dale loves the hobby, says he meets a lot of great people, as we all do and is glad he is in the club.



Continued on page 3

What's Wrong With This Picture? (con't) *by Terry Brim*

Continued from page 2

Dale bought the 72 LT1 from a local Springfield, Ohio dealer in Oct 2001. The car is loaded with tilt telescopic steering wheel, PS, PB, factory hard top, PO2 hubcaps and the ultra rare Air Conditioning! Less than 250 of these rare 72 LT1s were made with AIR. In fact, he believes that less than 50 of them were convertibles making this beautiful car even all the more rare.

Both of his LT1s are Red with Black leather interior, 4-speed and rear window



defroster. Talk about a matched pair!

The car only has 41K original miles and is headed for Top Flight... way to go Dale!

Less than 250 of these rare 72 LT1's were made with AIR.

Dale is currently looking for a red 70 LT1 to complete his C3 LT1 stable.

As if that weren't enough, the car had a

survivor award back in 1996. Dale is currently looking for a red 70 LT1 to complete his C3 LT1 stable, so if any of you out there know of a red 70' LT1 I'm sure Dale would like to hear from you!



The step- child in Dale's

collection is a beautiful 65" fuelie which he bought at the Bloomington auction in 2004. Dale says the car was originally restored in Alabama and runs great.

The car is equipped with PS, side exhaust, power antenna, knockoff wheels and of course the fuel injection. There is yet an

other story behind this car, but I'll leave that up to Dale to share with our readers over a beer sometime!

Dale says the LT1s are keepers, especially if he is lucky enough to locate the missing 70' LT1 to complete his ultra rare collection.

Good luck with your search Dale, maybe one of our readers will steer you to a winner. Additional photos of Dale's collection on page 4.

**What's Wrong With This Picture? (con't) by Terry
Brim**



The Nuts and Bolts of Nuts and Bolts by Patrick Ofenloch

Could you imagine how difficult our life would be with out the threaded fastener? Fasteners allow us to assemble a variety of components together with reliability, safety and ease. Many of us tighten nuts, bolts and screws everyday. Most items of our cars are assembled using threaded fasteners. Fasteners can be fascinating in how they actually work. Sometimes we don't think about what is actually happening.

Let's first look at a few of a few basic mechanical properties of steel. Steel actually reacts in many ways like a rubber band or a spring. Steel stretches and has an elastic property. The steel can be stretched and will return to it original shape for many cycles. This is known as the elastic limit. Sometimes this is also called plasticity or ductility.

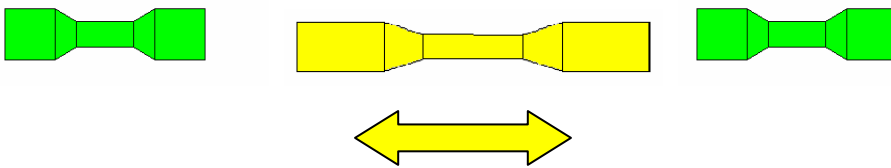

If we continue to exert more force on the steel it no longer returns to it original shape. This is known as the plastic deformation of steel.

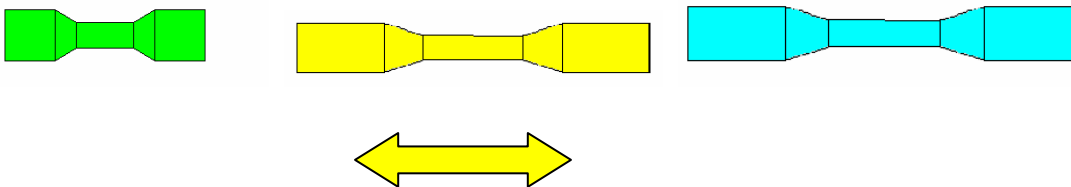

If we continue to exert even more force the metal fractures. The term actually is called the tensile strength which is the maximum load in tension a material with withstand before fracturing.

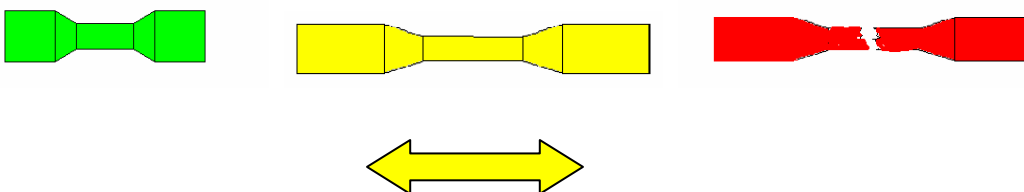

Now that we have some of the basic mechanical properties let's continue.

Continued on Page 6

The Nuts and Bolts of Nuts and Bolts (Con't)

by Patrick Ofenloch

Continued from Page 5

Bolts are pretensioned by turning them until they are snug, then using a twisting force (torque) from a specialized torque wrench or adjustable impact hammer to further turn the bolt. Since the head of the bolt is snug against the washer or surface, turning the bolt actually elongates or stretches it. We are taking the material to a yield point where plastic deformation is now taking place. The elongated bolt acts as a stretched spring, pulling the two materials together. This is also called the pretension force.

If we over tighten the bolt beyond this yield point the bolts ability to be reused will be limited. Like the example above if we continue to over tighten the bolt we have two pieces. One piece of the bolt in the component and the head of the bolt in our hand. This is not a good thing. In the event this does happen there are a few ways to restore a thread.

Torquing bolts

As a rule, when a bolt is installed, the nut (over a washer) should be turned and not the bolt's head. Unless a torque wrench is used the tendency is to under tighten large bolts and over tighten small ones. Suggested torques are given below.

Approximate Torque Settings for Cadmium-Plated Bolts Not specially lubricated, in foot-pounds

Bolt diameter in inches

Bolt Grade	¼	5/16	3/8	7/16	½	9/16	5/8	¾	7/8	1
SAE 2	4.6	9	15	24	36	50	69	117	184	273
SAE 3	6.9	14	24	38	57	82	113	198	317	477
SAE 5	7.5	15	25	40	59	83	114	196	309	459
SAE 6/7	9.7	19	34	55	83	120	166	291	469	710
SAE 8	10.5	21	37	60	90	130	180	316	509	769
Socket Head Cap Screws	12.7	25	45	72	109	157	217	381	615	929

Continued on Page 7

The Nuts and Bolts of Nuts and Bolts (Con't)

by Patrick Ofenloch

Continued from Page 6

These suggestions do not apply if the bolt or nut has been specially lubricated.

Bolt definitions

Did you ever wonder what was being said you hear the car parts counter person yell out, “where are the 3/8-16 coarse threaded bolts”.

Here are the definitions.

3/8”- 16 UNC – 2A

3/8 inch (.375 “) Major diameter

16 threads per inch. 1.000” /16 threads per inch. Each revolution moves the bolt .0625 of an inch forward.

UNF Unified fine thread these types of threads have a greater tensile strength. These are used when the resistance to stripping is greater. Length of thread engagement is shorter. Most used in automotive and Aerospace applications.

UNC Unified Coarse thread. Generally used in lower tensile strength materials such as cast iron.

UNEF Extra fine thread series. Used mostly in thin wall material.

Bolt Classification

A is for an external thread

B is used to specify an internal thread

1 for special applications

2 are normal production tolerance

3 minimum tolerances.

Bolt Grades.

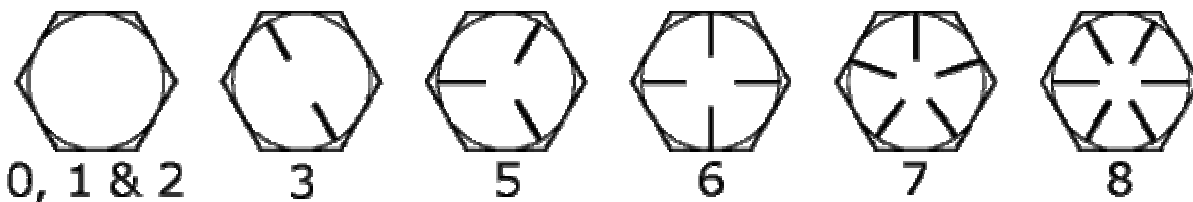

SAE grades on bolt heads

Continued on Page 8

The Nuts and Bolts of Nuts and Bolts (Con't)

by Patrick Ofenloch

Continued from Page 7

The SAE (society of Automobile Engineers) has established a sequence of grades from 0 to 8 for steel bolts, on the basis of the metal from which the bolt is made and the manner of how it is manufactured. Available grades run from 2 to 8, with 8 the strongest. Higher grade numbers almost always mean increased strength (an exception is that some grade 6 bolts are stronger than grade 7). The heads of steel bolts are marked to identify their grade.

It isn't always a good idea to replace a bolt with a stronger one. Some bolts are deliberately chosen so that they are weak enough to fail before the stress or strain damages some more expensive or critical part of the equipment. For the same reason, in making furniture cabinetmakers use glues that are weaker than wood. That way, if the furniture is overloaded, the joints break. It is much easier to reglue a broken joint than to replace a piece of broken wood.

Interesting facts:

When using a bolt actually the first thread takes a third of the load, the first three threads take three-quarters of the load, and the first six threads take essentially the whole load. Beyond the first six threads, the remaining threads are under basically under no load at all. This is because of the stress properties the bolt undergoes while being stretched.

Once tightened, what makes a bolt loosen? Vibration is often thought to be as the chief culprit, but several studies indicate the main reason is insufficient preload, allowing side-to-side slippage of the bolt relative to the bolted joint members. For that reason, preload, or residual tension, in a tightened bolt actually is more important to assembly strength than the strength of the fastener itself. In a joint, a bolt torqued to its proper load level can resist a maximum amount of external load without loosening. In fact, an installed bolt is tightest when stressed as closely as possible to its elastic limit.

Hopefully now we have a new respect and understanding for threaded fasteners. We can all have a bad day sometimes. Our friends the threaded fasteners are threaded , stretched, graded, strained, and under stress all the time.

Lost Owner

I am an NCRS member #1610

Could you help me with the following by a putting a brief version of my query below in your chapter newsletter and/or by giving me the name and contact number of any members in your chapter that you think might be able to help me.

I am trying to determine the first owner (i.e. years 1965-1967) of my 1965 Corvette Coupe red int/ext 4 speed 4:11 rear gears 365hp radio tinted windows. The Corvette vin# 194375S112826 was delivered as a new car March 11, 1965 to Edgewater Chevrolet formerly located in Cleveland Ohio on Detroit Ave. The car was sold as a used car around 1968 by V.V.Cooke Chevrolet Limited formerly of Louisville, Kentucky. The second owner was a Donnie Gardner formerly of Buffalo Ky. now of Elizabethtown Ky. who worked in parts department at V.V.Cooke Chevrolet.

V.V.Cooke Chevrolet of Louisville was, in those years, one of the biggest Corvette dealers in the U.S. and bought both new and used Corvettes from other Chevrolet dealers so my Corvette may have been either:

- (i) dealer traded to V.V.Cooke as new car and sold by V.V.Cooke as new car
- (ii) sold as new car by Edgewater Chevrolet & bought by V.V.Cooke as used car
- (iii) sold by Edgewater Chevrolet & first owner moved to Ky. and traded car in at V.V.Cooke

As a result I am looking for anyone who might remember the Corvette in the Cleveland, Ohio area in the years 1965-1967 even if they do not remember owners name. Especially if they remember car in dealership showroom.

The States of Ohio and Kentucky purged their older DMV records and so no ownership history records are available for years 1965-1967.

I have talked to the second owner and a few older retired employees from both Edgewater Chevrolet & V.V.Cooke Chevrolet but no luck in terms of determining the first owner's name or positive confirmation which of the two dealerships actually sold my Corvette as a new car.

I would appreciate any help you can give.

Thanks.

Bill Keogh
63 Glenridge Ave
St.Catharines, Ontario
Canada L2R4W9
Tel 905-9843908 work 905-6824210 home

E-mail: bill.keogh@ccra-adrc.gc.ca

[New 1957—1965 Corvette Fuel Meter Covers](#)

[by Larry Linder](#)

Problem: I have a broken 65 fuel meter cover and there are none on the planet.

The fuel meter cover sits on top of the fuel meter, it mounts the vent filter that is under the steel cover (silver cad), the vent tube that connects to the plenum, and most import the diaphragm cover. Under the covers is the needle and seat, rectangular float mounting pylons and depending on the year a circular pylon protruding downward above the spill valve. It connects the fuel inlet filter and the starting bypass lines in 57 and 65. It is a very important part of the injector and the reproduction of the part was most difficult because of the variation in design over the years and its multitude of fittings and functions.

Background: The fuel meter covers are easily damaged because they were a diets part and the fuel filter on some models is cantilevered at the fuel inlet fitting. Anytime you change the filter, fuel pump or bump the fuel line there is the possibility of breaking the inlet part of the cover. Some have use Teflon tape to seal inlet fitting but managed to break their cover by over tithing the fitting. Every time the diaphragm cover screws are tightened or removed to replace the diaphragm the mounting screws get looser and then strip out. There have been a limited number of covers available from cannibalized units and all but a few have been used up. Repairs have been to weld up the covers, remember these are die cast, and re machine the inlet / bypass port, try to get the float pylons aligned, and then discover that as you remove weld to make it look presentable you find pits and different colors of metal. When you are done it may not work, its expensive and ugly to say the least. Not what you want for your car. Before going on the hunt for a used cover one needs to know what to look for and find out what fits what production year.

Covers Used in production:

Figure 1 is an early 57 fuel meter cover. It can be identified by a large circular barrel shaped sprew near the fuel inlet. This was used on early and mid 57 production. It also uses a short vent tube.

Later 57 covers can be identified by it lack of the pylon on the bottom side under the diaphragm cover , no anti siphon cover protrusion in cover , no vent tube hole, and a 3/16 fuel bypass connection in a boss near the fuel inlet.

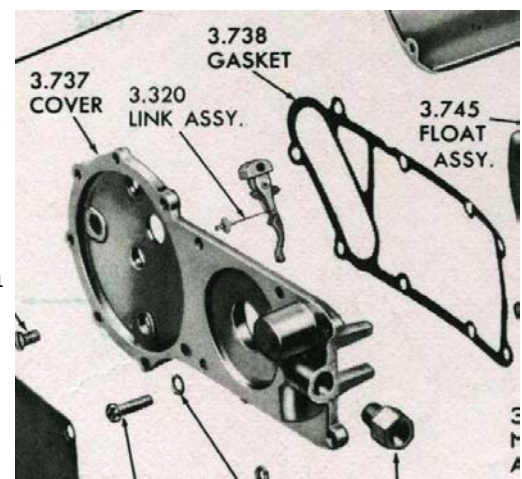

Figure 1 Early 57 FI Fuel Meter Cover

Continued on Page 11

New 1957—1965 Corvette Fuel Meter Covers (con't) **by Larry Linder**

Continued from Page 10

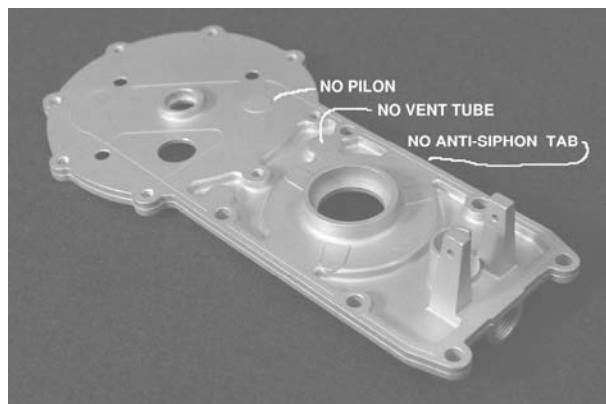

Figure 2: 57 FI Fuel Meter Cover Bottom

Figure 3: 57 Fuel Meter Cover Top is unique because of its small starting bypass line that directs fuel directly from engine fuel pump to spiders and absence of anti siphon cover projection, vent tube hole, and large projection at sprew (to bottom of fuel inlet).

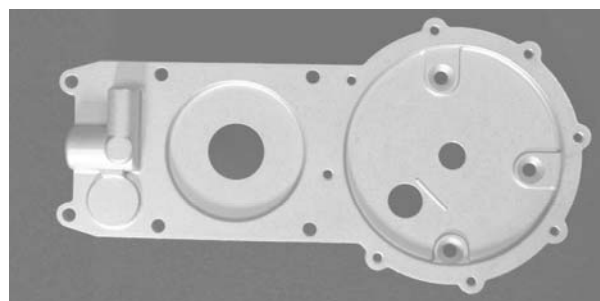

Figure 3: 57 FI Fuel Meter Top View

58- 62 (PN:) A 58 - 64E cover is similar to the 57 -1. This cover has the same small boss for the fuel bypass line as the 57 but it is not drilled. It also has an cover projection to cover the anti-siphon valve (top center), it has a conical pylon under the diaphragm cover that is over the fuel bypass valve. Figure 4 is the top view of the 58 - 64E.

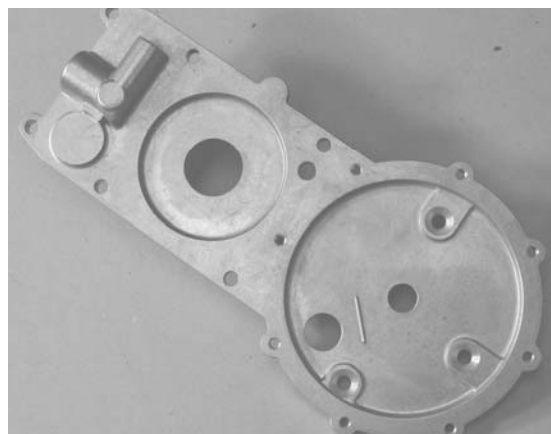

Figure 4: 58-64E FI Fuel Meter Top View

Continued on Page 12

New 1957—1965 Corvette Fuel Meter Covers (con't)

by Larry Linder

Continued from Page 11

Figure 5 is the bottom view of the 58-64E. The vent tube hole and anti-siphon projection are in front center of the cover. The pylon is clearly visible the imagined angle is due to graphics distortion. You can see the milled section on float pylons. This assures correct float clearance. Original covers are not milled and the float fit is sloppy causing need/seat problems.

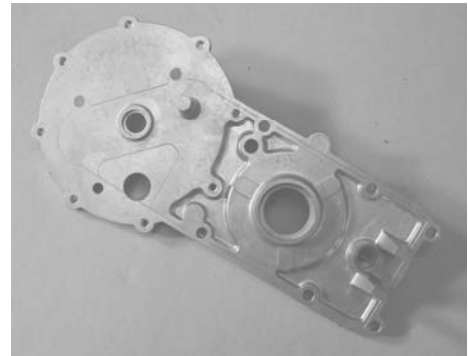

Figure 5: 58-62 FI Fuel Meter Cover Bottom View

64L – 65 (PN:)This cover is like the 58 – 64 but has a much larger boss on the inboard side for a 1/4 -28 threaded hole for a brass fitting that connects to a 3/16 fuel bypass line. this line connects directly to the starting solenoid which connects to the spider.

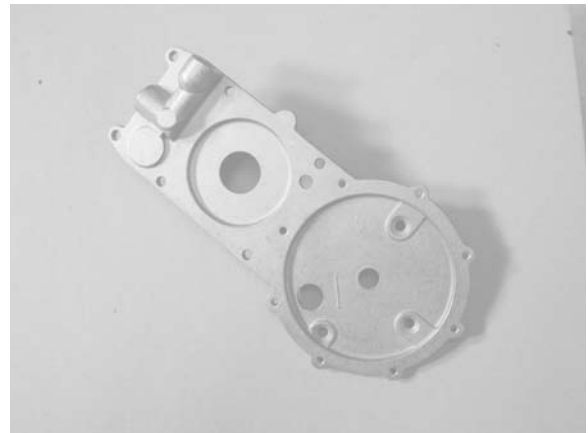

Figure 6: 65 FI Fuel Meter Top View

Bottom view/inboard side view of the 65 cover showing the threaded hole in the enlarged boss to the left side. Note the gasket traces, these are necessary to make sure the gaskets seal properly. Covers that have had these polished off in an attempt to flatten the cover will cause a fuel seepage around the edges of the fuel meter cover.



Figure 7: 65 FI Fuel Meter Bottom View

Continued on Page 13

New 1957—1965 Corvette Fuel Meter Covers (con't)

by Larry Linder

Continued from Page 12

Now that we knew what we were looking for we were unable to find acceptably good covers at any price. The alternative was to build our own but with some important improvements.

Design improvements: Rules of the game. All design improvements must be non detectable from the outside.

1. Most of the improvements are in the type of material used for the castings and closer tolerances. Some areas are thicker for added strength in critical areas such as under the fuel inlet. The material is a higher strength aircraft quality aluminum alloy that has the same finished color as the original and good machining characteristics. This reduces the likelihood of a broken cover due to the cantilevered fuel filter, over torquing the fuel inlet fitting, and higher strength threads for the diaphragm cover. All holes and critical dimensions are machined to maintain tolerances, such as the float mounting pylon to float clearance.

2. Correct parting line in the casting: Getting the parting lines correct was a challenge as the original part was cast using a die cast as in (match plate). The new covers had to have different spews (vents where metal is poured

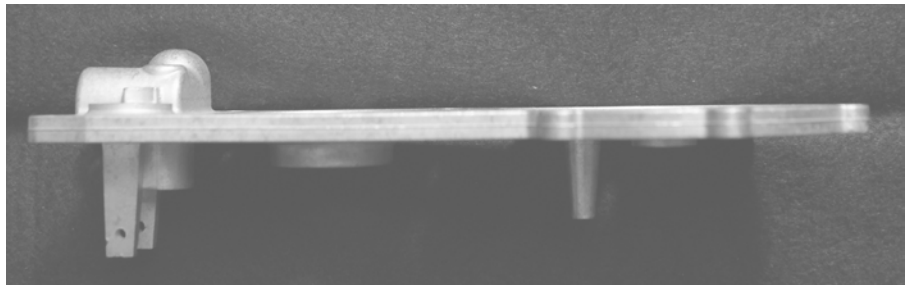

into or gases leave), to make sure the mold is filled evenly and completely. With a CNC mill and a special tool the spews were removed so they are very difficult to detect their presences.

3. Cover flatness, and accuracy of the mounting and hole placement. One problem with most thin casting is that they are subject to warp. These casting are straightened in a manner to protect the gasket traces. These are the small raised trace that makes the gasket seal properly. Never sand the bottom of a cover to straighten it as you will destroy the ridge that makes the gasket seal.

Continued on Page 14

New 1957—1965 Corvette Fuel Meter Covers (con't) **by Larry Linder**

Continued from Page 13

How we designed the covers:

We built a complete set of casting prints and machining prints for each cover in a CAD system. The prints were then printed as 1:1 on a plotter. An optical comparator was used to measure the location of all holes and machined surfaces, between known original parts, sections of parts, an NOS fuel meter and diaphragm cover to make sure everything fit perfectly. After we accomplished this we found that there was a mistake in the original prints that was never corrected!

The CAD drawings were processed by a casting CAM software to produce the pre-warped dimensions for machining the molds. The pre-warping is necessary to compensate for metal shrinkage. If the molds were identical to the part – the parts would be small by some dimension after they cooled. The CAM software complains bitterly about any line in the drawing that was not a perfect junction, this a common problem with most CAD and CAM systems. A sample set of covers were produced and checked against good original covers, machined and fit to an injector pump for testing - perfect fit.

The covers as delivered from the foundry are very presentable. During the machining operation every critical dimension and surface is machined using a CNC mill and a number of fixtures to hold the cover in position. The end result of the careful attention to all details is a reproduction cover that is identical to the original. When placed side by side the people picked up the reproduction and said “that this was the original cover” or could not tell the difference.

Three of the four covers are reproduced, the 57-2, 58-64E, and 64L-56.

The second 57-1 cover was not included because it was only used for several months of production and a number of original spares exist.

Assemble it correctly:

Use a thread sealer such as "leak lock" (no Teflon tape) to seal fittings, avoid fuel leaks and over torquing. A very small amount of "leak lock" is applied to start of threads and the fittings installed in the cover. Let it dry for a few hours. There will be no visible compound on the threads and it will never leak. A good flare nut wrench is necessary to remove fittings. Leak lock is solvable in acetone – low temp lacquer thinner.

Remember even a small flake of Teflon tape and your injector will never operate again without an expensive overhaul and maybe a new spider.

Continued on Page 15

New 1957—1965 Corvette Fuel Meter Covers (con't) ***by Larry Linder***

Continued from Page 14

After we built some for my own use a number of folks wanted fuel meter covers for their units. A number were cast and machined and are now available from MicroControls in Xenia, Ohio.

See the FI Spiders at "micro-controls.com" look in the Corvette parts section of their web site.

Several quality restoration shops have these fuel meter covers:

John Degregory
649 Humphrey RD
Greensburg, PA 15601
1 724 832 3786

Jim Thorpe
C / O
Sue McIntyre
PO Box 563
Andalusia, IL 61232
1 309 798 5129
suezque61@sbcglobal.net

The contents of this article are the sole opinion of the author.

Larry Linder

Ads and Services

Small Block Chevy Bare Block 3914678 302-327-350CID

Date A 708

Freshly Machined Ready to use +.040 Bore

No Sleeves /De rusted

Typical used in 1968

\$495 Performance Clinic 937-426-3247

Services:

MEDIA BLASING

Need your parts cleaned? I can
remove rust, paint, grime, etc.
\$30 per hour.

Call Greg: (937) 369-5519

Rental/ For Sale:

Transmission Floor Jack.
New Professional model, Heavy duty.
\$50 per week or will sell for \$275.

Call Greg: (937) 369-5519

58



**Van Leeuwen
Upholstery**
Antique furniture restoration since 1957

326 Mary Ellen Drive
Dayton, Ohio 45419-4152
(937) 293-1212

TOM VAN LEEUWEN

Office Hours By Appointment



TERRY L. POWELL, D.D.S.
Family Practice

214 W. National Rd.
Englewood, OH 45322
Telephone: (937) 836-4747
Home: (937) 339-1636

C3 Build Sheet Removal *by Ed Kayler*

A friend of mine owns a machine shop and one of his unusual but necessary tools is a lighted bore scope. I used this scope to view around my rubber gas filler neck (you can carefully push it out of the way) and see if the tank sticker was still attached to the gas tank of my 72 BB coupe. There it was and in apparently very good condition. I decided that a piece of paper exposed to the elements for 30 years should be removed and preserved in a safe place.



Be sure to wear safety goggles and disconnect your battery during this process. The first step is to drain the fuel tank, with a mechanical siphon. I found a cheap one at Harbor Freight that worked great. The next step is to block the front wheels and raise the rear end of the car. Be sure to place jack stands under the frame.

Next, unbolt the rear most muffler hangers and loosen the muffler clamps next to the half-shafts. This will allow you to push the mufflers out of the way of the spare tire holder and the gas tank. Remove the spare tire. Remove the spare tire holder by removing the long mounting bolts with a crescent wrench.

Next, you will need to prepare the

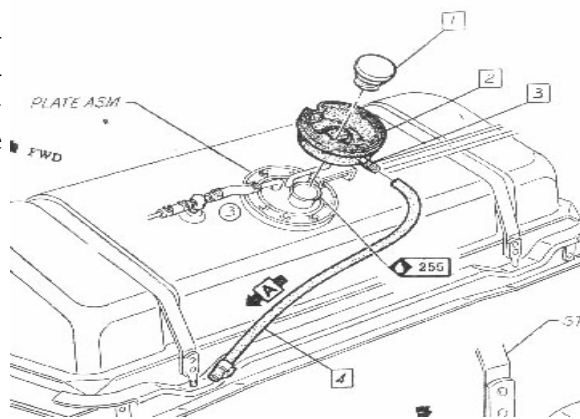

gas tank for lowering. Remove the rubber gas filler neck. Remove the gas gauge electric lines. There are two wires for this on the right side of the filler. You will most likely be able to see the three lines that run to the tank, after you have removed the filler neck. The two gas lines are located on the right side, and the evaporator line is located on the left. It will be easier to remove these lines after lowering the gas tank a few

inches. You must be careful not to bend or break these lines.

Next, remove the two nuts from the gas tank straps that hold the gas tank to the mounting cross member. Place a floor jack below the tank with a 2x4 across the jack. Jack the floor jack up to rest against the bottom of the

tank. Before you proceed, REMEMBER, you still have the 3 fuel lines attached, and you only want to lower the tank

a few inches! Remove the bolts holding the tank in place and lower the tank a few inches. Now you should be able to see and get your hand in from the filler area to pull the build sheet. If the sheet happens to be glued to the tank AND one of the straps, it will begin to tear if you lower the tank further. Check to see if you can locate the build sheet. I've read several articles that claim the tank sticker is usually located on the

Continued on page 20

Members Corner **By Nick Kammer**

In an effort for us to get to know each other a little better we will feature brief bio's of our fellow members. If you haven't submitted your member profile I would encourage you to do so. You can give as much or as little info as you want. You will find the 'Members Profile' form in our quarterly newsletter accessible at our website.

See page 28 for Members profile form. Fill out and return to Nick Kammer to get your profile published in the next issue of our Vette Gazette

For calendar/upcoming events and for sale items/parts wanted items see the chapter web site:

www.ncrs.org/mvc

WELCOME NEW MEMBERS!

Mike Glaunsinger

David Heitzman



Pete Cerar, CRB

When it comes to buying or selling real estate, put your trust in two names that count!

- Dayton area's No.1 real estate firm
- Pete's extensive knowledge - over 30 years experience in real estate
- A wealth of resource to help you buy or sell a home
- Sales leader club every year in business

Office: (937) 434-7600

Home: (937) 299-2999

E-mail: pcerar@coldwellbankerdayton.com

Website: www.pcerar.com



HERITAGE REALTORS®

Miami Valley Chapter Officers

Chairman:

Larry Linder (22779)
937-426-4832 After 6PM
Fax – 937-347-1193
ljinder@sbcglobal.net

Vice Chairman/Advertising**Chairman:**

Ed Kayler (36775)
937-748-2004
ekayler@rixan.com

Secretary:

Terry Buchanan (32872)
937-429-3434 After 6PM
buchanant@sbcglobal.net

Treasurer:

Greg Gorniak (25258)
937-426-8122
red65vette@hotmail.com

Judging Chairman:

Mike Ammer (17574)
937-434-8897
mikeammer@sbcglobal.com

Newsletter Chairman:

Terry Brim (39588)
937-429-0281 (H)
937-430-1281 (C)
mvcbrim@woh.rr.com

Membership Chairman:

Nick Kammer (33307)
937-848-3022
Nick.kammer@ncmc.com

Rules Chairman:

Jerry Michaels (36147)
937-866-8703
jerned@aol.com

Events Chairman:

Mike Mills (40661)
937-748-5039
937-241-5868 (c)
Michael.mills5@wpafb.af

Continued from page 1

book entitled “Best Italian eateries in the US”. D'Antonio's downtown Celebration was fantastic, the “real deal” in Italian food.

For the 06 Chapter Judging event we are going to need a lot of Judging help because a regional is being held on the same date in St. Louis. A good opportunity to attend some judging schools, earn judging points and enjoy the event.

If any of you have a favorite charity - please nominate them to be a recipient of a Chapter donation and National NCRS matching funds.

I am getting an itchy foot and getting ready to do some more cruising as soon as the weather breaks.

A new program is for the NCRS is to identify new NCRS members and have a local chapter contact them, invite them to come to the meeting and join up.

New Name badges (inserts) will be available February's meeting. New holder for new members and some spare parts for the rest.

Hope to see yea all at the Next Meeting and definitely at the next cruise.

Keep on smiling and the world will wonder what you have been up too.

Regards
Larry



MIAMI VALLEY CHAPTER

C3 Build Sheet Removal (con't) by Ed Kayler

Continued from page 17

upper front side of the fuel tank on the driver's side of the car. My tank sticker was located on the top passenger side. Only one small part of the top left corner was torn off and the writing was very legible. All I did was slowly pull the paper off the tank; the glue was still pliable and forgiving.

If you have managed to recover your build sheet you'll notice it's nothing more

than old cheap printer paper with the perforations on the sides for feeding through a dot-matrix printer. Be very careful to handle it gently. Do not brush at the paper, because this will only cause

further deterioration. I store my sheet in a transparent sheet protector and I use acid free paper as a backing.



If only I could reach the pedals....someday, someday

First Annual Founders Day Dinner

The first annual Founders Day Dinner of Miami Valley Chapter of the NCRS was held on February 18, 2006 at the Five Seasons Country Club. As can be seen, a good time was had by all with

good food, friends and fellowship. A special thank you to the day chairperson for the event Ed Kayler and committee members Terry Buchanan, Freddie Haugh, and Debbie Hiney.



CHARTER STATEMENT

The Miami Valley Chapter of NCRS was formed on February 18, 2003 for the Corvette enthusiasts in the greater Dayton, Ohio area. Our Mission is to promote enjoyment, knowledge and restoration of the Corvette with fellow members of the National Corvette Restorers Society.



First Annual Founders Day Dinner



Minutes of First Meeting

The founding meeting of the Miami Valley NCRS was held this evening at Tumbleweed restaurant on Dorothy Lane Ave in Kettering. Those present were Jerry Black, Terry Buchanan, Greg Gorniak, Larry Linder, Jerry Michaels, Jamshid Moradmand, Tom Sliemers, and Jim Stukenborg. We discussed many issues regarding a Chapter formation. Larry has requested an information packet from the National NCRS. It should arrive within the next few days. Greg Gorniak collected \$5.00 from each person present to help mailing costs to a membership base that is now forming.

We decided to meet again on Tuesday, February 25 at 6pm at the Tumbleweed Restaurant in Kettering. We will review the report that Larry is working on to determine if we will be able to form an official chapter. After that we hope to go forward with a mass mailing to prospective members.



First Annual Founders Day Dinner



A special thank you to the contributors of our door Prizes

Hau-C Express

Miami Valley Chapter of NCRS

MicroControls

Mid America Motor Works

Rixan

Salley Tool and Die

Skyline Chili, Beavercreek

Steak & Shake, Beavercreek

Volunteer Vette Products



Members Corner

Name: Mike Glaunsinger

Significant other's name: Belinda

Date/place of birth: Charlotte, NC

NCRS#: 29080

Place of employment or occupation and brief description of what you do:

Retired from communications industry. Presently doing Corvette restorations and restoration work at my home in Spring Valley.

What other interests/hobbies do you have?

Corvettes are about it!

Under the heading 'Complaints take a number, solutions come on in', what do you like about our Chapter and what could be done to improve what we do?

Since I am a new member and have not been to any meetings, I do not have any comments at the present time.

First car ever owned:

52 Chevy

First Corvette owned:

71 LT1

Present Corvette's), classic cars owned:

1967, 1972, 2000 Corvettes

Members Corner

Name: Jamie Schade

Significant other's name: Agata

Date/place of birth: 07/06/73 Dayton, Ohio

NCRS#: 29080

Place of employment or occupation and brief description of what you do:

Merrill Lynch—Financial Advisor

What other interests/hobbies do you have?

Golf, Fitness, Almost any outdoor activity!

Under the heading 'Complaints take a number, solutions come on in', what do you like about our Chapter and what could be done to improve what we do?

I'm pretty new to the chapter and haven't participated in enough events to comment....though I'm impressed with the organization of events.

First car ever owned:

Ford Ranger XLT

First Corvette owned:

1994 Red Corvette Coupe

Present Corvette's), classic cars owned:

2002 Black convertible

Members Corner

Name: Ed Kayler

Significant other's name: Elena

Date/place of birth: Sept 4, 1949 Dayton, Ohio

NCRS#: 36775

Place of employment or occupation and brief description of what you do:

Rixan Associates, Inc. Director of Customer Service (which is a fancy way of saying I fix broken Mitsubishi industrial robots and help solve customer problems) Have tools, will travel.

What other interests/hobbies do you have?

Collecting stuff, hunting and travel

Under the heading 'Complaints take a number, solutions come on in', what do you like about our Chapter and what could be done to improve what we do?

I wish our visitors and guests would be made more welcome and "fussed" over. My partner is Russian and she has enlightened me as to an Old Russian saying: "A visitor to your house is a gift from God"

First car ever owned:

65 Ford Custom 500

First Corvette owned:

68 white coupe 327/350hp

Present Corvette's), classic cars owned:

72 BB coupe, 01 Convertible

Members Corner

Name: Veit Von Parker

Significant other's name: Jacqueline

Date/place of birth: March 27, 1958 Dayton, Ohio

NCRS#: 43794

Place of employment or occupation and brief description of what you do:

Display Dynamics, Inc., President/CEO. Full service designer and builder of museum and tradeshow exhibits.

What other interests/hobbies do you have?

Model trains

Under the heading 'Complaints take a number, solutions come on in', what do you like about our Chapter and what could be done to improve what we do?

Possibly reach out to a younger audience promoting the hobby and marque.

First car ever owned:

1962 Buick Invicta 2 Door

First Corvette owned:

1965 327/365 Air Coupe

Present Corvette's), classic cars owned:

1965 327/365 Air coupe and 1965 396/425 Roadster

Miami Valley Chapter

National Corvette Restorers Society

Member Profile

In an effort for us to get to know each other better we will include in our quarterly newsletter 'Vette Gazette' our members profiles. Whatever facts you wish to share with the rest of us are welcome. If you wish to submit a member profile just complete the profile below and send it to the web address listed below. Input on how we can improve our Chapter is also encouraged. If you would like for me to take your information over the phone just call me at 937-297-3611. Otherwise send the profile as an attachment to your return e-mail back to me (see bottom of page).

Name:

Significant others name: _____

Date/place of birth: _____

NCRS # _____ (we have this on file but other members may find this an interesting tidbit of information.)

Place of employment or occupation and brief description of what you do

What other interests/hobbies do you have? _____

Under the heading 'Complaints take a number, solutions come on in', what do you like about our Chapter and what could be done to improve what we do? _____

First car ever owned _____.

First Corvette owned _____.

Present Corvette's), classic cars owned _____

Thanks for your input and information.

Forward this profile to Nick Kammer, Membership Chairman

www.nick.kammer@ncmc.com